

# 10 CHANNELS HIGH SPEED TRIGGERING CONTROL DEFECT UNIT

**UDR10**

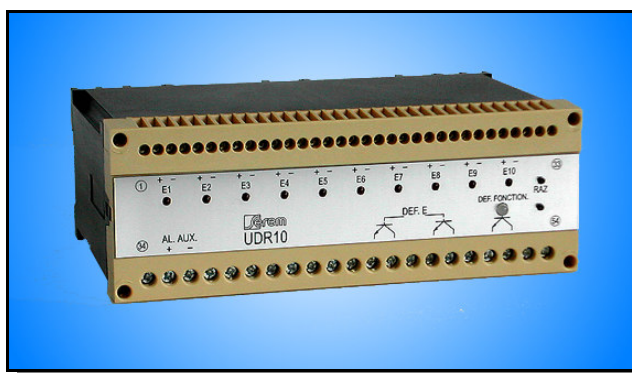

## FUNCTION

The module UDR10 detects and controls 10 defects simultaneously. Each opto-isolated input allows an ultra fast detection of the defect and verifies electrical wire continuity of the channel. A detected defect activates 2 output static relays (IN.FAULT). Each electrical wire discontinuity or breakage unit deactivates an output static relay (FUNCTIONING DIAGNOSIS).

Front LEDs signal each input defect, breakage module or electrical wire discontinuity.

## ELECTRICAL CHARACTERISTICS

**Inputs :** 10 optically isolated channels,  
2 levels of detection ("continuity of line" and "input defects"),  
activation on "1" or "0" state,  
possibility of memorization state .  
configuration:  
-with or without detection of line continuity,  
-contacts active on " opening " or active on " closing ",  
-with or without fault memorization,

**Outputs :** "FUNCTIONING DIAGNOSIS" for running or continuity defect :  
1 static relay, 30 V / 100 mA max.,  
"IN. FAULT" for "input faults" :  
2 static relays, 2 – 60 VDC / 3 A max.,  
Operate time : 0,3 ms, release time : 1 ms,

**Display of states :** 10 red LEDs and a bi-colour LED  
(green : normal functioning, red : line continuity defect).

**Reset of memorisation :** by PB on front side  
**Insulation I / O & Ix / Iy :** 2 500 Vrms for 1 min.  
**Temperature range :** -20 to 60 °C  
**Power supply :** 24 VDC (-50/+30%)

### In accordance with the CE norms

No continuous magnetic field influence up to 150 Gauss, in the 3 directions.

## MECHANICAL CHARACTERISTICS

**Casing :** polycarbonate case for din profile.  
**Junction :** 2 screw terminals 33 & 21 pins.  
**Dimensions :** 200 x 73 x 118 mm.

**Weight :** 750 g.



**ELECTRONIQUE INDUSTRIELLE**

## DIMENSIONS

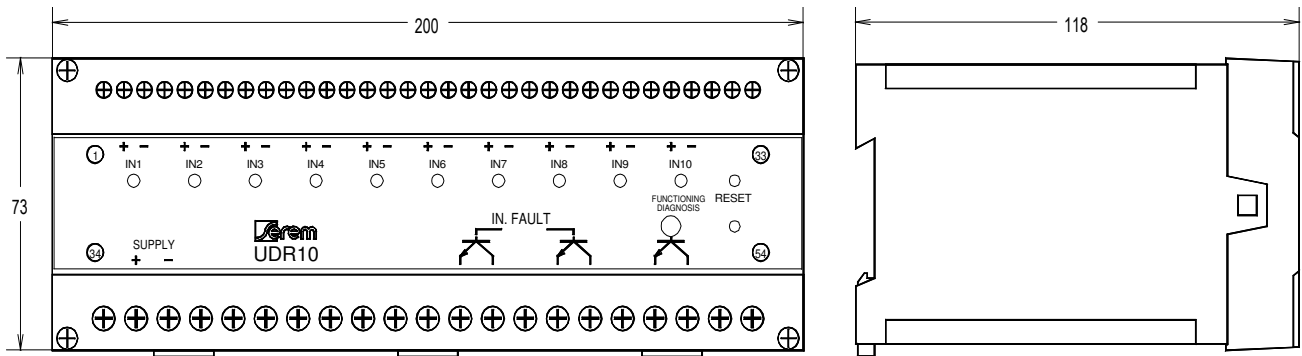

## JUNCTIONS

TERMINAL	DESIGNATION
2	Input IN1 +
3	Input IN1 -
5	Input IN2 +
6	Input IN2 -
8	Input IN3 +
9	Input IN3 -
11	Input IN4 +
12	Input IN4 -
14	Input IN5 +
15	Input IN5 -
17	Input IN6 +
18	Input IN6 -
20	Input IN7 +
21	Input IN7 -
23	Input IN8 +
24	Input IN8 -
26	Input IN9 +
27	Input IN9 -
29	Input IN10 +
30	Input IN10 -
35	Supply Voltage +
36	Supply Voltage -
45	IN. FAULT emitter
46	IN. FAULT collector
48	IN. FAULT emitter (Bis)
49	IN. FAULT collector (Bis)
51	Functioning Diagnosis emitter
52	Functioning Diagnosis collector

## TABLEAU of INPUTS CONFIGURATION

	Line continuity detection		Memorization of default		No memorization	
	YES	NO	active on closing	active on opening	active on closing	active on opening
I1						
I2						
I3						
I4						
I5						
I6						
I7						
I8						
I9						
I10						

## INPUTS WIRING

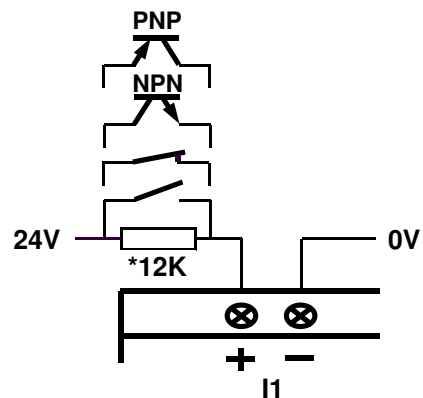

\* R only for line continuity detection in case contact is set active on closing.